

POSline TRF9300/TRF9310

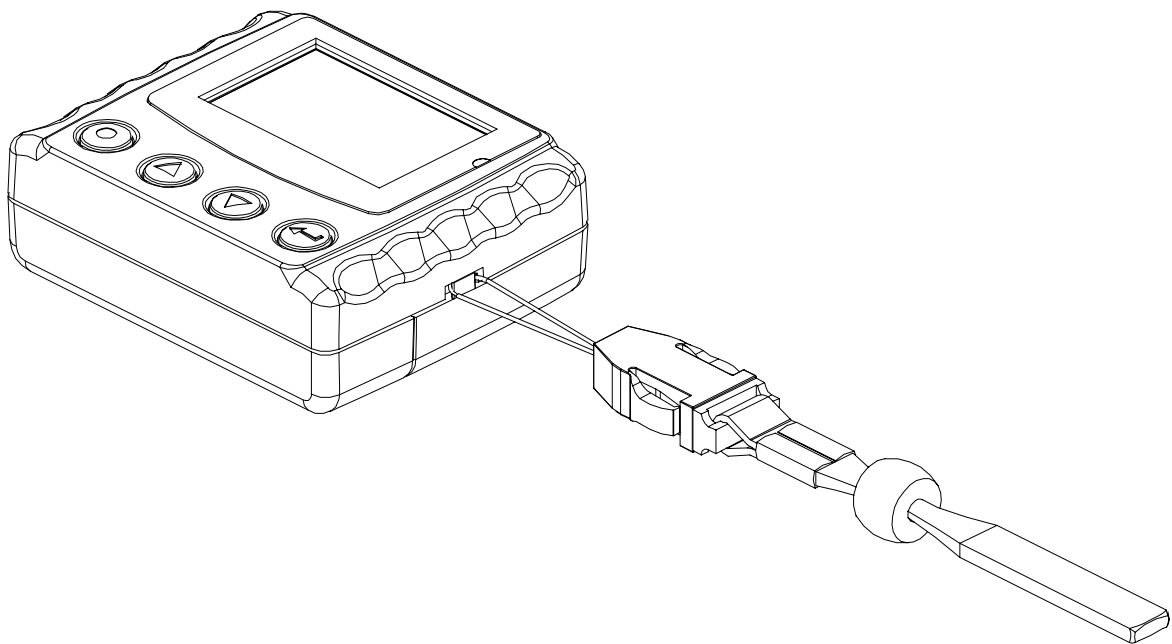

RFID Card Reader with LCD User's Manual

Information in this document is subject to change without notice. No part of this document may be reproduced or transmitted in any form or by any means, electronic or mechanical, for any purpose, without the express written permission of POSline.

REVISIONS

Rev Number	Date	Notes
01	March. 07	Initial Release

Contents











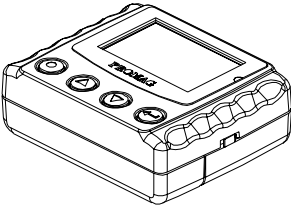

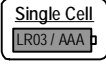
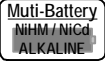
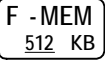

Information	4
Technical and Operational Description	7
Connections	13
Card Data Format	15
Specifications	16
Communication Protocol	17

FCC COMPLIANCE STATEMENT

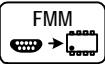
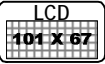
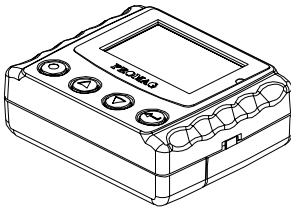
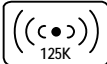
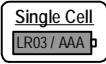
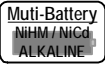
This equipment has been tested and found to comply with the limits for a Class A digital device, pursuant to Part 15 of the FCC Rules. These limits are designed to provide reasonable protection against harmful interference when the equipment is operated in a commercial environment. This equipment generates, uses, and can radiate radio frequency energy and, if not installed and used in accordance with the instruction manual, may cause harmful interference to radio communication. Operation of this equipment in a residential area is likely to cause harmful interference in which case the user will be required to correct the interference at his own expense.

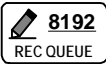
Information



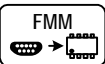
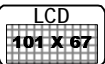







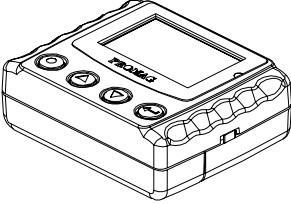

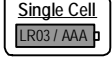
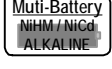
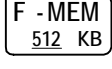

TRF9300 125KHz RFID Reader

MACHINE TYPE	FUNCTION
 <p>TRF9300 RS232 Interface</p>	           
 <p>TRF9300 USB Interface</p>	           

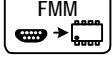
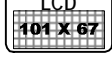
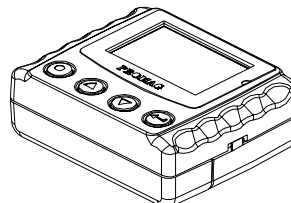
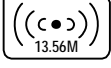
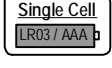
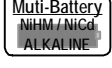
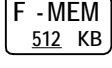
Read the instructions on your device before installing batteries

1. Insert batteries into your device properly, with the (+) and (-) terminals aligned correctly.
2. Discharged batteries should be removed from equipment to prevent possible damage.
3. Store the batteries in a cool and dry place. [Batteries should be stored at temperatures between 50°F (10°C) and 77°F (25°C), with relative humidity not exceeding 65 percent. Refrigeration of alkaline batteries is not necessary because of their very good capacity retention. Excessive temperature cycling and storage at temperatures greater than 77°F (25°C) should be avoided to maximize shelf life.]
4. Remove batteries from the electrical device if the device is not going to be used for a long time.
5. Keep battery contact surfaces and battery compartment contacts clean by rubbing them with a clean pencil eraser or a rough cloth each time you replace batteries.
6. Keep batteries away from children. If swallowed, contact a physician at once.
7. Don't recharge a battery unless it is specifically marked "rechargeable". Attempts to recharge an alkaline battery may cause an imbalance within the cell, leading to gassing and possibly explosion on either charge or discharge cycles.
8. Don't dispose of batteries in a fire—they may rupture or leak.
9. Don't carry loose batteries in a pocket or purse with metal objects like coins, paper clips, etc. This will short-circuit the battery, generating high heat.

TRF9310 13.56MHz RFID Reader

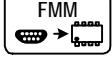
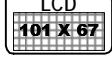
MACHINE TYPE	FUNCTION
 <p>MRF120 RS232 Interface</p>	           
 <p>MRF120U USB Interface</p>	           

Read the instructions on your device before installing batteries

1. Insert batteries into your device properly, with the (+) and (-) terminals aligned correctly.
2. Discharged batteries should be removed from equipment to prevent possible damage.
3. Store the batteries in a cool and dry place. [Batteries should be stored at temperatures between 50°F (10°C) and 77°F (25°C), with relative humidity not exceeding 65 percent. Refrigeration of alkaline batteries is not necessary because of their very good capacity retention. Excessive temperature cycling and storage at temperatures greater than 77°F (25°C) should be avoided to maximize shelf life.]
4. Remove batteries from the electrical device if the device is not going to be used for a long time.
5. Keep battery contact surfaces and battery compartment contacts clean by rubbing them with a clean pencil eraser or a rough cloth each time you replace batteries.
6. Keep batteries away from children. If swallowed, contact a physician at once.
7. Don't recharge a battery unless it is specifically marked "rechargeable". Attempts to recharge an alkaline battery may cause an imbalance within the cell, leading to gassing and possibly explosion on either charge or discharge cycles.
8. Don't dispose of batteries in a fire—they may rupture or leak.
9. Don't carry loose batteries in a pocket or purse with metal objects like coins, paper clips, etc. This will short-circuit the battery, generating high heat.

■ Standard Package

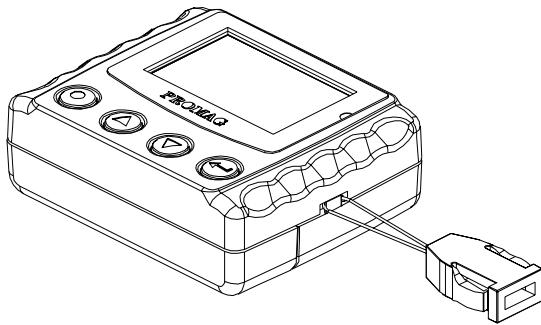

**Main unit
(TRF9300/TRF9310)**

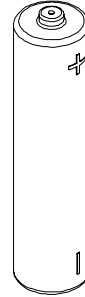

LR03-AAA ALKALINE 1.5V Battery

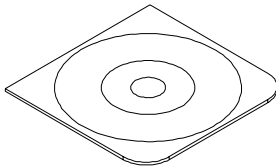

CD-ROM

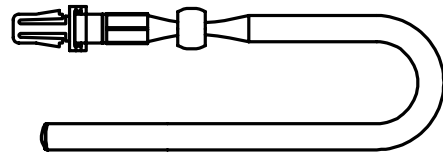

Chain Sling

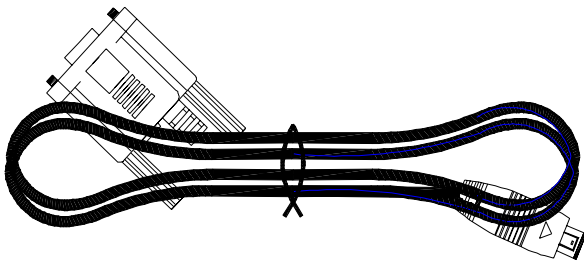

RS232 Cable for TRF9300/TRF9310

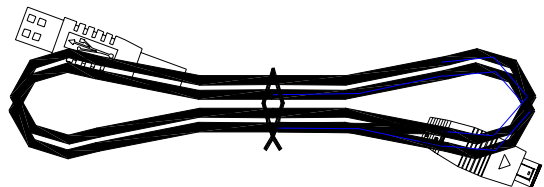

USB Cable for TRF9300/TRF9310

Technical and Operational Description

Front Panel and Operations

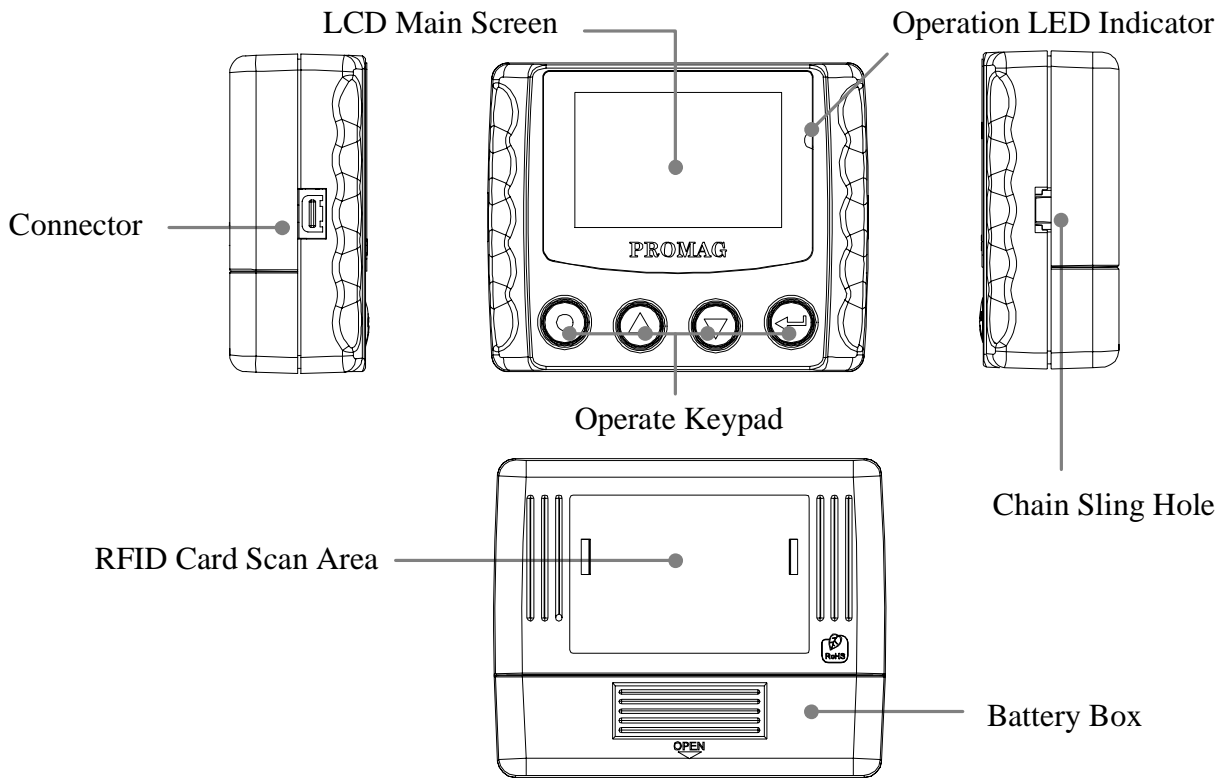

- **RFID Card Scan Area**
Scan the RFID card to reader.
- **Operation LED Indicator**
When encountering erroneous input, defective card, misread, bad memory or incorrectly encoded data and so on, the device will turn on the ERROR indicator .
- **LCD Main Screen**
Indicating the device is ready for use low battery in operational mode.
- **Connector**
For connection to host computer and external Power .
- **Battery Box**
Put the battery in box and hold battery .
- **Operate Keypad**
Turn the TRF9300/TRF9310 on/off power and Operate.
- **Chain Sling Hole**
Connect to chain sling.

■ LCD Display

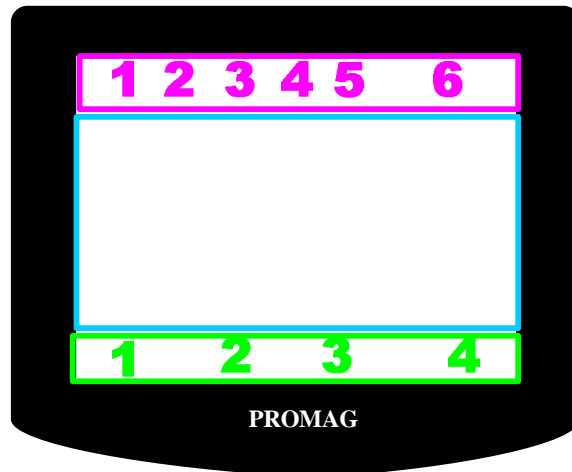



Status Function Area

Main Display Area

Keypad Guidance Area

● Status Function Area

1. Power Status

-  Battery Power Supply
-  Low Battery Power Supply
-  External Power Supply

2. Scan Status

- / or \ Scanning

3. Buzzer Status

-  Buzzer ON

4. Event Status

- 1~9 Event

5. Decode Status

- EM EM Card Decoded
- 1K Mifare 1K Card Decoded
- 4K Mifare 4K Card Decoded
- DS Mifare DESFire Card Decoded
- UT Mifare Ultralight Card Decoded
- FL Felica Card Decoded

6. Guidance Number

- xxxxxxx Current Record Number When Scanning or Viewing Database
- x Main Menu Item When Operating Menu
- x-x Sub-Menu Item When Operating Submenu

● Main Display Area

Display Date & Week & Time , Menu Item , Record Data , Parameter Setting , Other Information

● Keypad Guidance Area

1. Corresponding Key -

Power /Exit / Back / Cancel / No Key Function

2. Corresponding Key -

Up / Up scroll / Decrease/Scan Key Function

3. Corresponding Key -

Down / Down scroll / Increase/Event Key Function

4. Corresponding Key -

Menu / Enter / Save / Next / Yes Key Function

■ Function Menu

1. Profiles	1-1. Machine ID	Display Machine ID - 2 Characters Default : 00
	1-2. User Name	Display User Name - 16 Characters Max
	1-3. Display Format	Display Mode - ID Number
	1-4. View Mode	Set View Mode - Big or Small Default : Big
	1-5. Scan Mode	Set Scan Mode - Button or Continuous Default : Button
2. Setting	2-1. BackLight	Set Back Light Duration - 00 ~ 255 Seconds Default : 15 Seconds
	2-2. Auto Power Off	Set Auto Power Off Duration - 00 ~ 255 Seconds Default : 30 Seconds
	2-3. Power Mode	Set Power Mode - Switch Mode or Auto Power Off Mode Default : Switch Mode
	2-4. Sound	Set Operate Sound - ON or OFF Default : ON
	2-5. Reset	Reset Default - BackLight = 15 seconds Auto Power Off = 30 seconds Power Mode = Switch Mode Sound = ON
3. Database	3-1. Status	Display Memory Status - Used Space, Unused Space, Total Space
	3-2. View	Display all records in memory
4. Calendar	4-1. Date Format	Set Date Format Select - Year / Month / Date Date / Month / Year Month / Date / Year Default : Month / Date / Year
	4-2. Set Date/Time	Set Date - Year, Month, Date Set Time - Week, Hour, Minute, Second
5. Information	5-1. Product Name, Product Description, Firmware Version	

■ Display Information

Exceptional Indication

LCD Display message	Description	Counterplot
Check RTC !	The RTC is malfunctioning (After scan card)	Set Date and Time
FLASH Full !	The record already is full. (After scan card)	Download Records and Erase Records
Check FLASH !	The record can't write into the FLASH memory. (After scan card)	Contact Agent
Decode Error !	Scan Card can't decode. (After scan card)	Scan Card again or Change Card
No Record !	No Record in FLASH memory. (Enter Database -View function)	Swipe Card
Record not empty !	The FLASH memory not empty. (Enter Calendar function)	Download Records and Erase Records
ISP MODE	Enter FMM Mode (By communication command)	Update New Firmware

LED Indicator

Status	Green LED	Red LED	Buzzer	Read Card
Power On	Take turns blink 2 times		Beep. Beep.	X
Auto Power Off	Take turns blink 2 times		Beep. Beep.	X
Ready	Off	Off	X	O
Read OK	Blink 1 time	Off	Beep.	X
Read Error	Off	Blink 1 time	Beep. Beep. Beep.	X
Firmware Management Mode	Off	On	X	X

■ Operational Description

1. Powered by Battery

For normal use, the unit is powered by battery. Push the Power Switch Button “⊙” for about 2 seconds to turn on the unit. Also push the Power Switch Button “⊙” for about 2 seconds to turn off the unit at Switch Mode. After the unit is turned on, the power would be turned off automatically if there is no scanning a card on the unit in 30 seconds (default) at Auto Power Off Mode. This means the unit would be turned off if no scanning a card again in every 30 seconds (default) after every card scanning. It would have Low Battery Detect/Warning indication when the unit is powered by battery.

2. Powered by Cable

When TRF9300/TRF9310 is connected/disconnected to external power adapter by the WAS-T0017 RS232 cable or USB port by the WAS-1571 USB cable,, it would be turned On/Off automatically. When the unit is connected with the PC through the communication Cable (WAS-T0017 or WAS-1571) and the PC is running TRF9300/TRF9310 software and the unit is turned on. Then you can do the unit Setting, Configuration or data downloading. When the device is powered by cable from PC, the Power“⊙” Switch would have no function and the unit would have no Low Battery Detect/Warning function.

3. Real Time Clock Setting

Before start using the unit, you must set the Real Time Clock (RTC) inside the unit to your local time. If there is no battery for quite a while or it is powered by cable for quite a while this would cause Real Time clock (RTC) malfunctioned due to no power supply. When put on the battery to turn on the unit and the Red/Green LED take turns to blinks, this means the RTC is malfunctioning and you must do the RTC time setting before you use the unit.

4. Low Battery Detect

When the device is powered by battery, it would have Low Battery Detect function. When the battery goes low, the LCD would display “” and you must change battery immediately ; otherwise, the unit would shut down any time without pre-warning.

5. Scan RFID Card

When TRF9300/TRF9310 is showing the status of any function on the screen, after presenting a RFID card to TRF9300/TRF9310 reader, TRF9300/TRF9310 is displaying card ID and record(s) information on the screen immediately. When TRF9300/TRF9310 is not working for next card scan, TRF9300/TRF9310 reader will back to default screen automatically.

6. Operate for Calendar

Before setting calendar function, please delete remaining records from TRF9300/TRF9310 reader, if there are records in the memory of TRF9300/TRF9310 , your operate setting for Calendar, TRF9300/TRF9310 reader will display ” Record no empty” on the screen.

7. Memory Full Warning

Log database memory is full. You are not able to add any new records. Free the log database memory by uploading the data to the PC.

8. Communication by WAS-T0017 (RS232 cable)

You must use external power when the PC connect to TRF9300/TRF9310 by WAS-T0017 RS232 cable, or else the communication is not action. You should press any key on TRF9300/TRF9310 until the communication is finished, if you don't use external power.

9. Firmware Management Mode (FMM)

FMM allows you to quickly upgrade your TRF9300/TRF9310 internal firmware via com port and also check validity of currently loaded firmware. Contact your dealer for most recent firmware upgrade files.

10. Database in memory

The TRF9300/TRF9310 allows you to manage database by software . The Logical Erase Database will logically clean the database. The Recovery Database will recover the previous erase and not yet covered database. The record pointer will return to the top of the database after any erase.

■ Replace Battery

Note:

1. Read the instructions on your device before replace new battery.
2. TRF9300/TRF9310 can used Single-cell alkaline, nickel-cadmium (NiCd), or nickel-metal hydride (NiMH) Battery

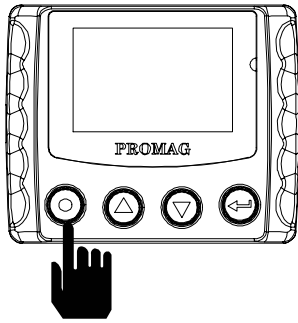

1. Power turn off



4. Take new battery

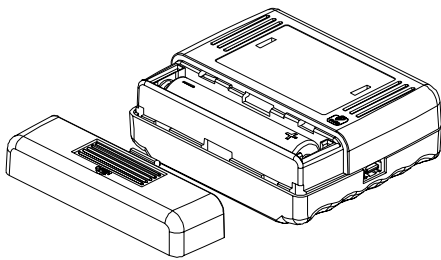

2. Take the cover away

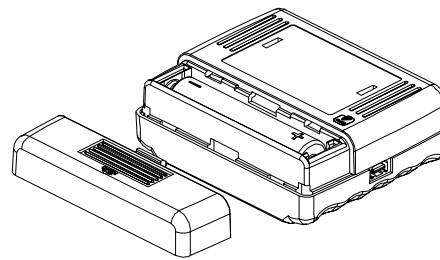

5. Put new battery in

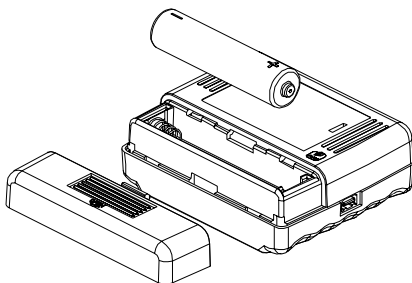

3. Take the battery away

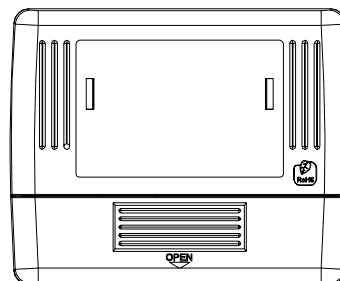

6. Fix the battery cover

Connections

WAS-T0017 RS232 interface cable



DSUB 9P POWER JACK	DSUB 9P FEMALE PIN	FUNCTION	MINI USB 4P
+		VCC +5V	1
	2	TXD	2
	3	RXD	3
-	5	GND	4

No use

Connect to PC

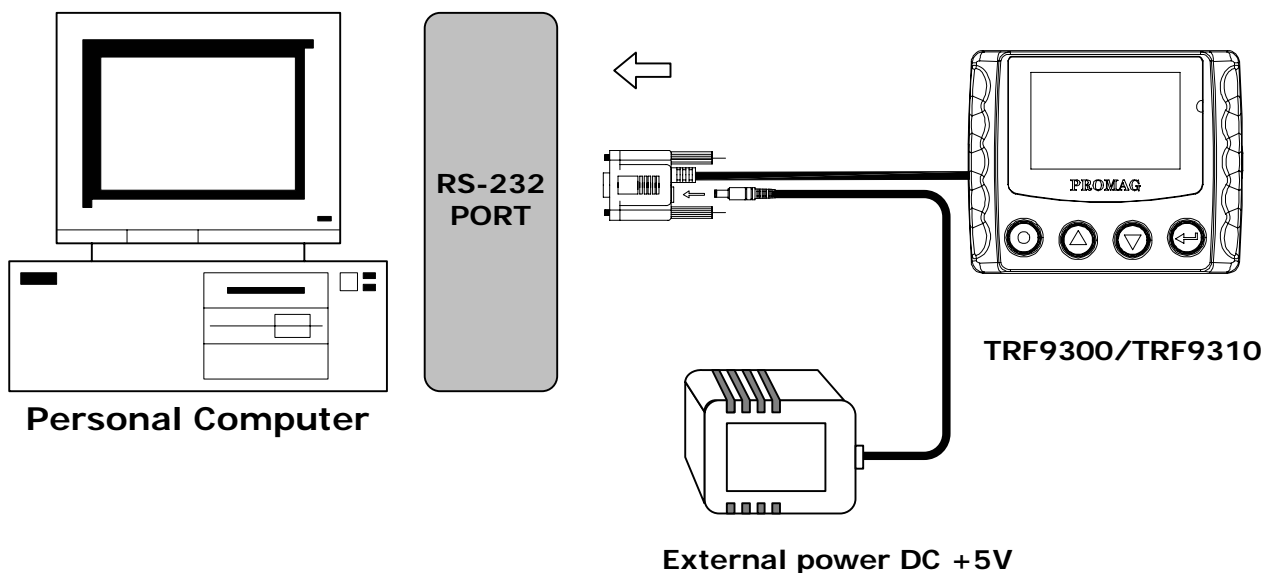

Note:

1. When TRF9300/TRF9310 is connected/disconnected with an external power adapter, it would be turned On/Off automatically.
2. When TRF9300/TRF9310 is not connected with an external power adaptor, the corresponding key for power on TRF9300/TRF9310 needs to be pressed all the time during the communications with the PC.

WAS-1571 USB interface cable



USB 4P FEMALE PIN	FUNCTION
1	VCC
3	D -
2	D +
4	GND

MINI USB 4P	FUNCTION
1	VCC
2	RXD
3	TXD
4	GNDTT

Connect to PC

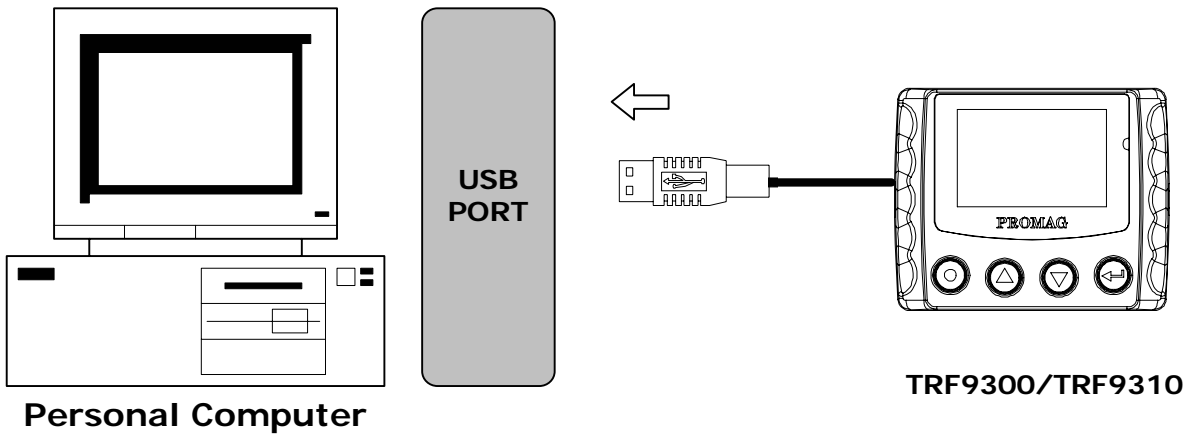

Note:

1. When TRF9300/TRF9310 is connected/disconnected with USB port, it would be turned On/Off automatically.

Card Data Format

CARD DATA STRING

STX	DATE & TIME	WEEK & CARD TYPE & EVENT	8 or 16 CARD ID	CR
-----	-------------	--------------------------	-----------------	----

STX	A	DATE	TIME	SP	WEEK	CARD TYPE	FC	CARD ID	CR
-----	---	------	------	----	------	-----------	----	---------	----

DATE & TIME

DATE	TIME	SP	WEEK
------	------	----	------

YYYY/MM/DD	HH:MM:SS	SP	W
------------	----------	----	---

MM/DD/YYYY	HH:MM:SS	SP	W
------------	----------	----	---

DD/MM/YYYY	HH:MM:SS	SP	W
------------	----------	----	---

1. Date have 3 formats - YYYY/MM/DD, MM/DD/YYYY, DD/MM/YYYY
2. SP is the SPACE characters (20h).
3. TIME is 24hrs .

WEEK & CARD TPYE

WEEK	
SUN	0
MON	1
TUE	2
WED	3
THU	4
FRI	5
SAT	6

CARD TYPE	
Mifare 1k	1
Mifare 4k	2
Mifare Ultrlight	3
Mifare DESFire	4
EM 125K	5
Felica	6

EVENT

EVENT CODE	EVENT
0	USER DEFINE EVENT
1	
2	
3	
4	
5	
6	
7	
8	
9	

Specifications

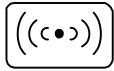

125KHz RFID Card for TRF9300

EM compatible 64 bits, ASK Manchester coding.
Reading distance 10~50mm (depends on card).

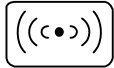

13.56MHz RFID Card for TRF9310

Compatible ISO 14443A, ISO 18092.
Reading distance 10~40mm (depends on card).



RS232 Interface

RS232 , Half-Duplex , 8N1 , 9600 bps



USB Interface

Full compliance with the USB Specification V 1.1
The device uses a Virtual Serial Port Driver, making it appear to have the software like a standard RS232 Serial Port.

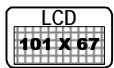

LCD Display

LCD type : FSTN
Dot arrangement : 101 x 67 Dots Matrix LCD Module
Viewing direction : 6 O'clock



Communication Protocol :

Version 1.2 (GNET V1.2)



CLOCK

Real Time Clock (RTC) module and back-up capacitor



Memory Size for Storing Data

CMOS Serial Flash Memory 512K bytes
Up to 8192 records (32 Bytes / Record)

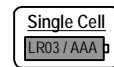

Battery Power

Single-cell alkaline, nickel-cadmium (NiCd), or nickel-metal hydride (NiMH) battery .



Power Supply from Cable

DC 5V , 200mA (for RS-232) or USB Powered

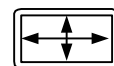

Dimensions

L 58 x W 20 x H 47 mm

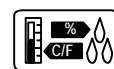

Environment

Operating Temp : 0 ~ +55°C
Storage Temp : -10 ~ +60°C
Humidity : 10 ~ 90 % relative

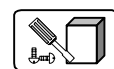

Mounting

Portable or Any surface

Communication Protocol

Handshaking

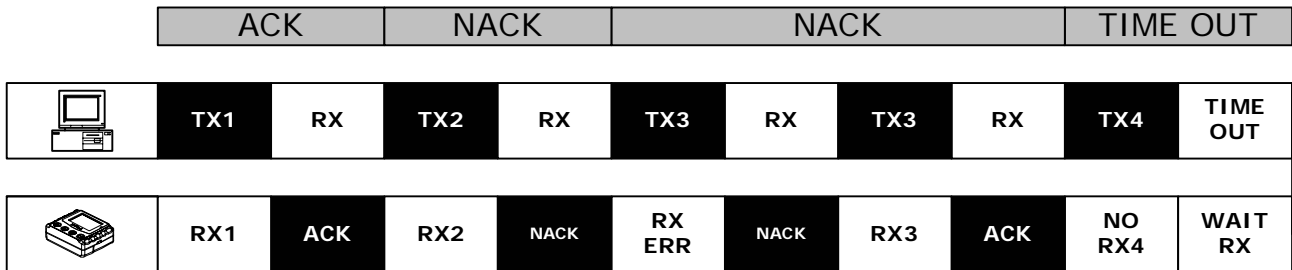

PACKET

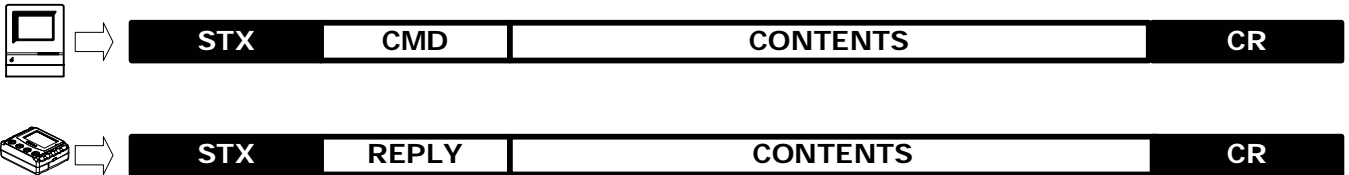

ITEM	Dec	Hex	Control Key	Function
STX	2	02	^B	Start of Text
CMD	ASCII	ASCII	ASCII	Command Code
CONTENTS	ASCII	ASCII	ASCII	Contents Data
CHKSUM	ASCII	ASCII	ASCII	Check Sum
CR	13	0d	^M	Carriage Return
REPLY	(78) 65	(4e) 41	(N) A	(Negative) Acknowledge

TRF9300/TRF9310 Terminal has an extensive list of Commands that allow manipulating its internal database, setting functional parameters and getting data on its current status.

There are 2 levels of access to the TRF9300/TRF9310 : User and Supervisor. Supervisor level is protected by a Password. Sensitive data can be downloaded or altered only on the Supervisor level. General Terminal data is available on the User level as well.

Command Index Table

Topic	Command		Contents	Description
Access Security Command				
ACCESS	U	L	4 Characters for Login(0000)	Login
	---	O	-	Logout
	S	P	New four characters password	Set Password
Database Commands				
DATABASE	U	N	-	Get Number of Record
	S	G	Number	Read Record by Number
	S	E	-	Erase All Record
	S	R	-	Rollback Record
	S	M	-	Recovery All Record
General Commands				
SETTING	U	F	-	Get Product Version
	S	S	Date,Time,Week	Set Date,Time and Week
	U	T	-	Get Date and Time
	S	J	-	Set Machine ID
	U	I	-	Get Machine ID
	U	X	-	Enter Firmware Management Mode
	S	B	-	Get Register
	S	C	-	Set register

Reply Index Table

Reply	Contents
A	Reply Information
C	Checksum Error
D	Access Denied
I	Invalid Command or Data
F	Command Execution Failed
E	Database is Empty

Access Security Commands

LOGIN : (for Supervisor Access Level)



PASSWORD | 4 Characters for Login. 0000=Initial value

EXAMPLE

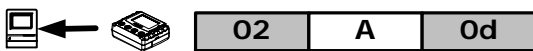

Login password : 0000

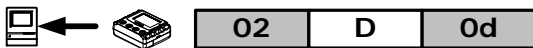

Login password command is not executed.

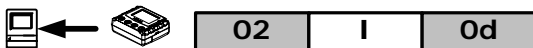

Invalid password.

LOGOUT :



EXAMPLE

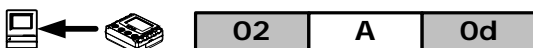
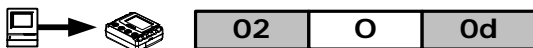

Logout

SET PASSWORD :



PASSWORD | New four characters password

EXAMPLE

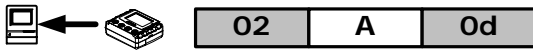

Set new password : 1234

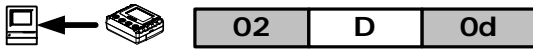

Set new password is not executed.

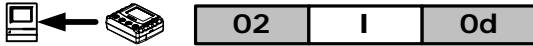

Invalid password

GET NUMBER OF RECORD :

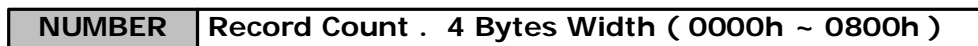

EXAMPLE

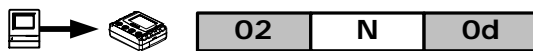

The total of record count : 12

READ RECORD BY NUMBER :



DATA	20h + Record Data
DATA TIME	DATE + TIME

EXAMPLE

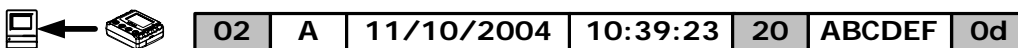

Record data : ABCDEF



Database is empty.

ERASE ALL RECORD :



* (Erase Duration : < 60 seconds)



EXAMPLE

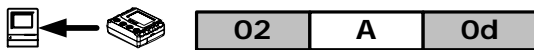
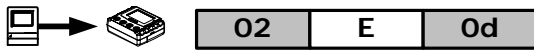

Erase all records.

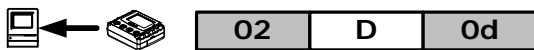

Erase command is not executed.

ROLLBACK DATABASE READOUT TRANSACTION :



EXAMPLE

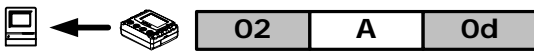
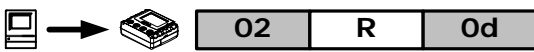

Database is rollback.

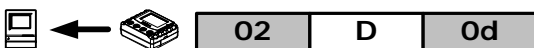

Command is not executed.

RECOVERY ALL DATABASE READOUT TRANSACTION :



EXAMPLE

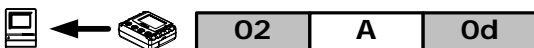
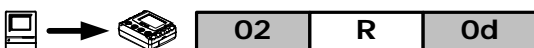

Database is recovery.

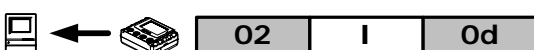

Invalid command .

GET PRODUCT VERSION :



ROM No.	ROM-Txxxx , xxxx : Rom serial number
VERSION	Vx.xxRm , Vx.xx : Firmware version x.xx , Rm : Modify m times

EXAMPLE

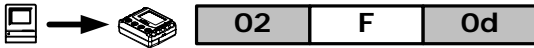

ROM serial number = ROM-T0571
 Firmware version = 1.03
 Modify times = 0

SET DATE AND TIME :

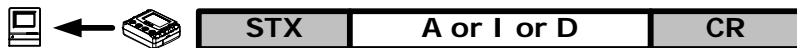

YYYY	Year (2000 - 20xx)
MM	Month (01 - 12)
DD	Date (01 - 31)
hh	Hour (00 - 23)
mm	Minute (00 - 59)
ss	Second (00 - 59)

EXAMPLE

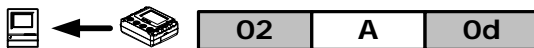

Set Date = 2000 / 5 / 5
 Set Time = 12 : 30 : 00 , Saturday

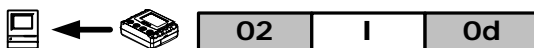

Invalid Date/Time

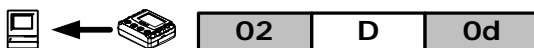

Set Date/Time is not executed.

GET DATE AND TIME:



EXAMPLE



Get Date : 2000 / 11 / 8
 Get Time : 14 : 20 : 31 , Thursday

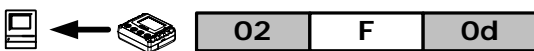

Get Date/Time is not set or invalid.

SET MACHINE ID:



EXAMPLE

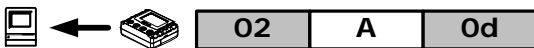

Set Machine ID : 00

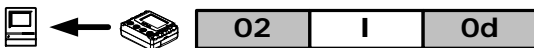

Invalid command or data.

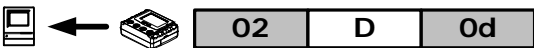

Set Machine ID is not executed.

GET MACHINE :

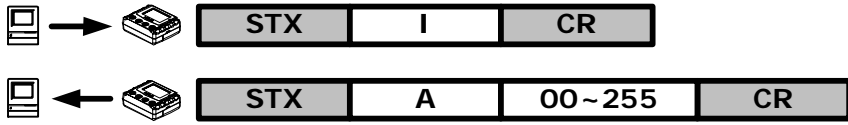

EXAMPLE

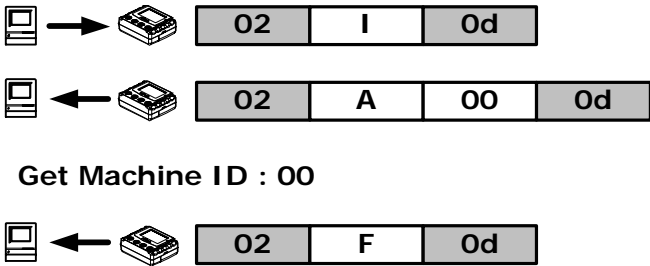

Get Machine ID : 00

Get Identification is not set or otherwise invalid.

ENTER FIRMWARE MANAGEMENT MODE :

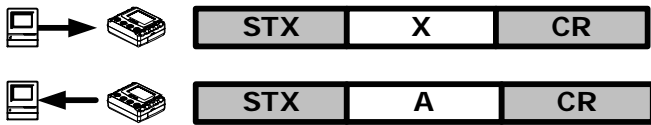

EXAMPLE

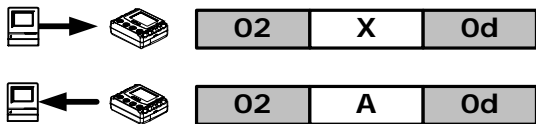

Enter firmware management mode

SET REGISTER :



REGISTER	Register Address . 2 Bytes Width (00h ~ FFh)
PARAM	Set Parameters of Register
CHKSUM	C + REGISTER + , + PARAM

GET REGISTER :



REGISTER	Register Address . 2 Bytes Width (00h ~ FFh)
PARAM	Set Parameters of Register

REGISTER TABLE

Register	Function	Description
10h	Auto Off Duration(Low byte)	00~FFh (0~ 255 second)
11h	Auto Off Duration(High byte)	-
12h	Power Mode	00h: Auto Power Off FFh: Switch Other: Real time
13h	Machine ID (High byte)	2 Characters
14h	Machine ID (Low byte)	
15h	RTC cal. value	00 ~ FFh
16h	*	*
17h	*	
18h	Back Light Duration	00~FFh (0~ 255 second)
19h	Buzzer	00h: Off FFh: On
1Ah	Date Format	00h: mm/dd/yyyy FFh: yyyy/mm/dd other: dd/mm/yyyy
1Bh	Display Mode	00h: Tracks Parallel 01h: Credit Card Mode other: Tracks Series
1C~1Dh	*	*
1Eh	Option of event	0~1h: only 0 event 2h: 0~1 event nh: 0~(n-1) event Max n=10 10~FFh: 0~9 event
1Fh	Scan Mode	00h: continuous Mode other: Button Mode
20~2Fh	User Name	16 Characters
30~1FBh	*	*
1FC~1FFh	Password	4 Characters